

# RECO NEWS

VOLUME 9: ISSUE 1

The Reinforced Earth Company

## Innovative Design and Construction: The New George Street Bridge New Brunswick, New Jersey

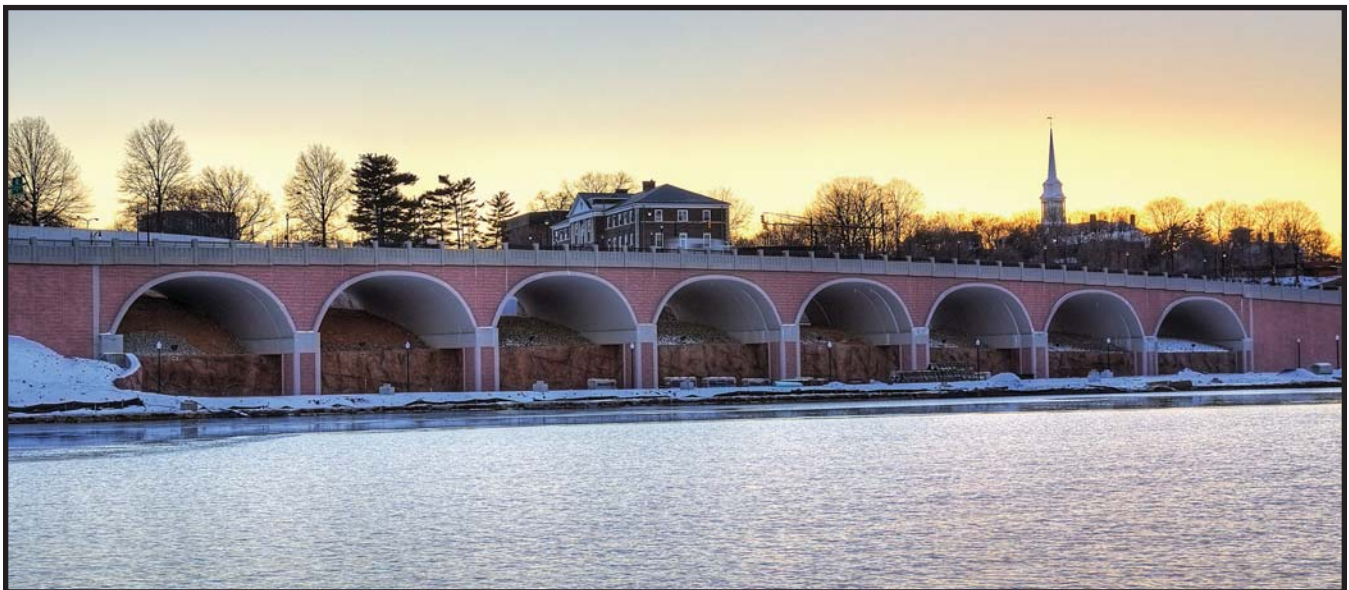

The Reinforced Earth Company (RECo) was contacted in the Fall of 2002 by Gannett Fleming, Hammonton, NJ to review and comment on a conceptual bridge design. The eight-barrel architectural arch bridge along the Raritan River waterfront in view of Rutgers University and the nearby Johnson & Johnson Company headquarters would ultimately become the centerpiece of the \$200-million project to reconstruct Route 18 in New Brunswick.

In March 2005 NJDOT awarded the general contract for the project to Conti Enterprises, Inc., South Plainfield, NJ. Subsequently, Conti selected RECo to design and supply the precast arches and

Mechanically Stabilized Earth (MSE) spandrel walls that comprise the core elements of the new bridge. RECo's contract with Conti also included furnishing design and materials for four MSE bridge ramps and seven retaining walls.

...continued on page 2

### What's inside

Walker Road Grade Separation .....	3
In support of Passenger Light Rail.....	4

continued from page 1...

## The George Street Bridge Design:

RECo's design employs the TechSpan™ Arch system, which consists of segmental precast arch units that form a three hinged arch structure. Two halves, a "male" and a "female" form the 66-ft span barrels. Each half arch unit weighs 33 tons. Installation of the TechSpan arch units was rapid. Each of the eight 60-ft long barrels was placed in two days.

These are the first TechSpan structures in the world to be constructed with lightweight concrete fill. The behavior of the arch during backfilling was different from those built with conventional granular fill. Therefore additional steel reinforcement at the crown was provided for this critical backfilling operation.

The forces in the precast pieces were computed using FLAC, a Finite Difference software.

The arch short-term deflection had to be calculated and monitored during erection. The accuracy in calculating the deflection resulted in a perfect fit for the spandrel panels. These facing elements were carefully placed so that all joints of the Random Cut Stone faux brick finish were in precise alignment.

The arches sit atop pier caps cast on top of drilled piers. The southernmost arches stand 6m +/- above the ground. To make sure that these piers did not displace under the horizontal force applied by the arch at its base, temporary tension rods were installed at each arch span during erection.

Equally challenging was the design and installation methods developed for construction of the full-height MSE spandrel walls. RECo developed a sophisticated handling and bracing scheme to secure the spandrel panels in place during the backfilling operation. RECo manufactured custom forming moulds to cast the 128 spandrel panels. Essential to the design was that the false joints of the stone block architectural pattern match consistently from one panel to the next.

The RECo project team included assistance from an affiliate company in Canada, Reinforced Earth Co. Ltd., Mississauga, Ontario. Having previously overseen installation of such large arches around the world, RECo Canada provided onsite technical assistance to the contractors in the field, further paving the way for speedy and trouble-free installation.

On January 2, 2009, with much fanfare the George Street Bridge was officially opened to traffic, a successful culmination of several years of coordination among the project teams. Contact RECo on your next short to medium span bridge or large culvert project to learn how you can save time and money with RECo as part of your project team.

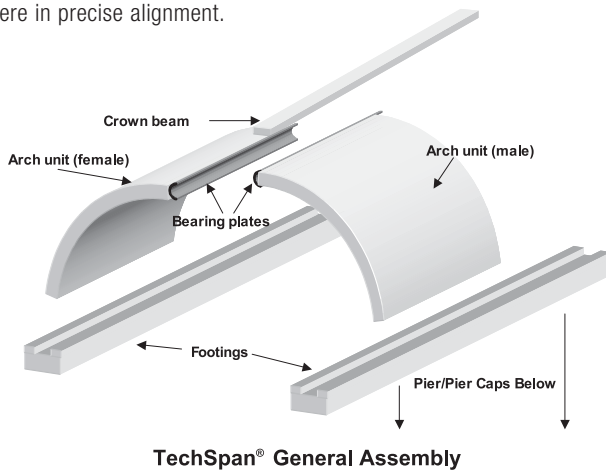

### Participants:

- Owner: New Jersey Dept. of Transportation, Trenton NJ
- Prime Consultant: Gannett Fleming, Hammonton, NJ
- Prime Contractor: Conti Enterprises, Inc., South Plainfield, NJ
- Subcontractor (Installation): Structural Services, Inc., Coopersburg, PA
- Precasting (Arches): Precast Systems, Inc., Allentown, NJ
- Precasting (MSE ): Concrete Safety Systems, Bethel, PA
- Design and Materials: The Reinforced Earth Co., Vienna, VA



Contact RECo to obtain TechSpan brochures, specifications, and construction video: [info@reinforcedearth.com](mailto:info@reinforcedearth.com), or by calling 800-446-5700

# Walker Road Grade Separation



**W**indsor-Detroit is one of the busiest border crossings between Canada and the United States of America (USA). As part of a program to streamline security across the border, an at-grade rail and road crossing on Walker Road in Windsor, Ontario has been grade separated. This project will also significantly improve traffic flow on this busy arterial road.

The concept chosen by Dillon Consulting for the grade separation was to depress the road corridor under the existing CP Rail tracks. Improvements to secondary crossing roads were also incorporated into the project. Utility re-location was also a major component of the project. Due to property constraints, it was initially expected that the excavation for the project would be achieved using secant piles along the project limits. Further assessment determined that open cut excavation with mechanically stabilized earth (MSE) retaining walls was also a viable option.

This project is a significant improvement to the City of Windsor's transportation network. It was decided early in the project development process that an architectural enhancement would be incorporated into the project retaining walls. After reviewing several options, "angle step" relief was selected for the architectural treatment. This treatment was combined with landscaping and handrail enhancements to create an aesthetically pleasing corridor for the public.

Walker Road was closed at the CP Rail crossing in the Fall of 2007 to enable construction of the grade separation. A detour network routed traffic around the road closure during the construction. With planning and co-ordination, the project was completed in one year and approximately one month ahead of schedule. Disruption to rail traffic was minimized during the work and traffic has flowed under the rail line since November 2008.

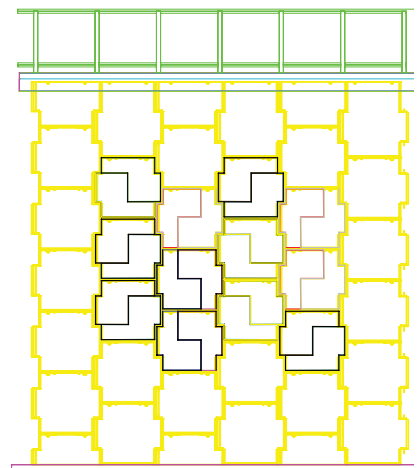

RECo's ANGLESTEP Pattern Layout



**IN SUPPORT OF PASSENGER LIGHT RAIL TRANSIT (LRT):**

**Reinforced Earth® Walls are an Essential Component of the Charlotte Area Transit System (CATS)**



The completion of Charlotte's South Corridor Light Rail Line adds yet another successful project to the long list of passenger rail projects by RECo. The ten-mile long Charlotte Area Transit System (CATS) employs extensive use of Reinforced Earth® walls supporting the electrified rail line.

In February 2005, CATS awarded Archer Western, Raleigh a contract for earthwork,

retaining walls, main station structures/platforms, among other essential elements of the 15 transit stations. Archer Western and subcontractors, The Artis Group, and Eckhart Construction Services, Inc. selected RECo to design and furnish a key component of the contract within an aggressive 18 month schedule: 267,000 square feet of Reinforced Earth® for six retaining walls and twelve abutments.

RECo engineers and project managers undertook the rigorous task of developing solutions for many challenging design cases. For example, the illustration shows a detail for a bridge abutment set to an acute angle of 48-degrees. The pile supported abutment was constructed in three phases. The fabrication and construction drawings for the facing panels, wall layouts, soil reinforcement, obstruction details, and phasing schemes were developed by RECo as part of the design and material-supply package furnished to the Archer-Artis-Eckhart team.

To accommodate obstructions posed by bridge piles, overhead catenary poles, and other

utilities, innovative details were developed by RECo to facilitate installation. RECo's "tie-strip" connection which anchors the soil reinforcements to the precast facing provided an installer-friendly solution when the soil reinforcements needed to be skewed to avoid obstructions.

Equally challenging was developing solutions to meet the architectural requirements of the project. The project required eight different architectural patterns for the more than 6,200 precast facing units. RECo was successful in developing solutions that assured the facings would fit neatly at abutments, in corners and around curves.

Contact RECo to learn how we can bring value to your next rail transit project.

**Participants:**

- Owner: City of Charlotte-Mecklenburg County, NC
- Prime Consultant: Parsons, Charlotte, NC
- Prime Contractor: Archer Western Contractors, Raleigh, NC
- Subcontractor (MSE Walls): The Artis Group, Lithonia, GA
- Subcontractor (MSE Walls): Eckhart Construction Services, Inc., Fort Mill, SC
- MSE facing precasting: Cherry Precast, Lewisville, NC
- MSE Wall Design and Materials: The Reinforced Earth Co., Vienna, VA

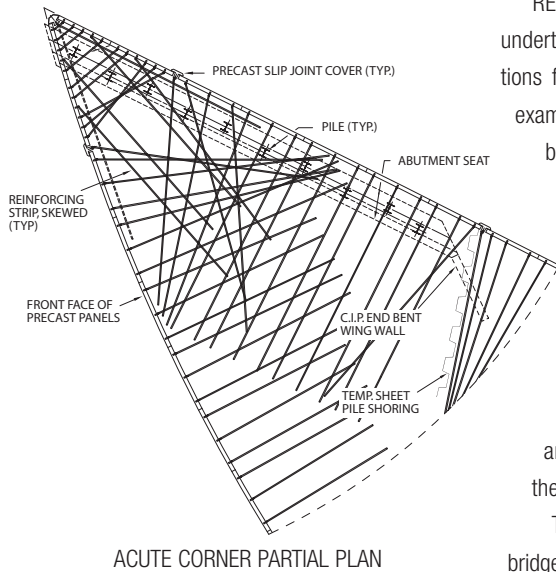

**In 1977, RECo designed and furnished the first MSE wall in the USA built to support commuter rail. The structure carries Atlanta's West Line Rail. Since then, RECo has designed and furnished commuter rail-MSE projects for the cities of Washington, Los Angeles, New York, Denver, Phoenix, Dallas, Cleveland, Portland, Seattle, San Diego, Boston, Minneapolis, San Jose, Sacramento, Miami, Newport News, Calgary, Edmonton, Vancouver BC, among others.**

**United States  
The Reinforced Earth Company**

8614 Westwood Center Drive  
Suite 1100  
Vienna, Virginia  
22182-2233  
Tel.: 1-800-446-5700  
Fax.: 703-821-1815

[www.reinforcedearth.com](http://www.reinforcedearth.com)

- Atlanta (770) 242-9415
- Boston (978) 664-2830
- Chicago (630) 898-3334
- Dallas/Ft. Worth (817) 283-5503
- Englewood, CO (303) 790-1481
- Orlando (407) 226-2840
- San Diego, CA (619) 688-2400
- Seattle (206) 409-0843
- Vienna, VA (703) 821-1175
- Woodbridge, VA (703) 499-9818

**Canada  
Reinforced Earth Company Ltd.**

1550 Enterprise Road  
Suite 229  
Mississauga, Ontario  
L4W 4P4  
Tel.: 1-800-263-7097  
Fax.: 905-564-2609

[www.reinforcedearth.ca](http://www.reinforcedearth.ca)

- Antigonish NS (902) 735-3900
- Edmonton AB (780) 453-8983
- Montreal QC (450) 646-4266
- Toronto ON (905) 564-0896
- Vancouver BC (604) 714-0766



**Reinforced Earth**

Sustainable Technology